



Softopper Exo Truck Bed Rack Installation Instructions

Please read the instructions thoroughly before starting the installation



Estimated Installation Time: 2 hours

Beginning Note: It is best to have a friend to help with the installation, especially when reinstalling the Softopper® after the rack has been installed on the vehicle. It is possible to install the rack without completely removing the Softopper®, but it is recommended to remove the Softopper® and reinstall it after the rack installation is finished.

****Safety Notes****

Please read the following before driving with the Exo Truck Bed Rack installed:

1. **DO NOT** rely in any way on the ExoO Truck Bed Rack to contain occupants or objects within the vehicle bed, or to protect against injury or death in the event of an accident or a roll-over.
2. The Exo Truck Bed Rack will not protect the occupants or objects from falling or flying objects. Never operate vehicle in excess of the manufacturer's recommendations or specifications.

Tools needed for installation:

1/2 inch socket
9/16 inch socket
1/2 inch wrench

Table of Contents

1. Inventory.....	3
2. Hardware Installation	
Bedrails.....	4
Uprights.....	5
Top Channels.....	6
Tent Bars.....	6
Accessory Panels.....	7
3. Soft Top Canopy Installation.....	8
4. Secure Rack and Softopper to truck.....	9
5. Warranty Information.....	11

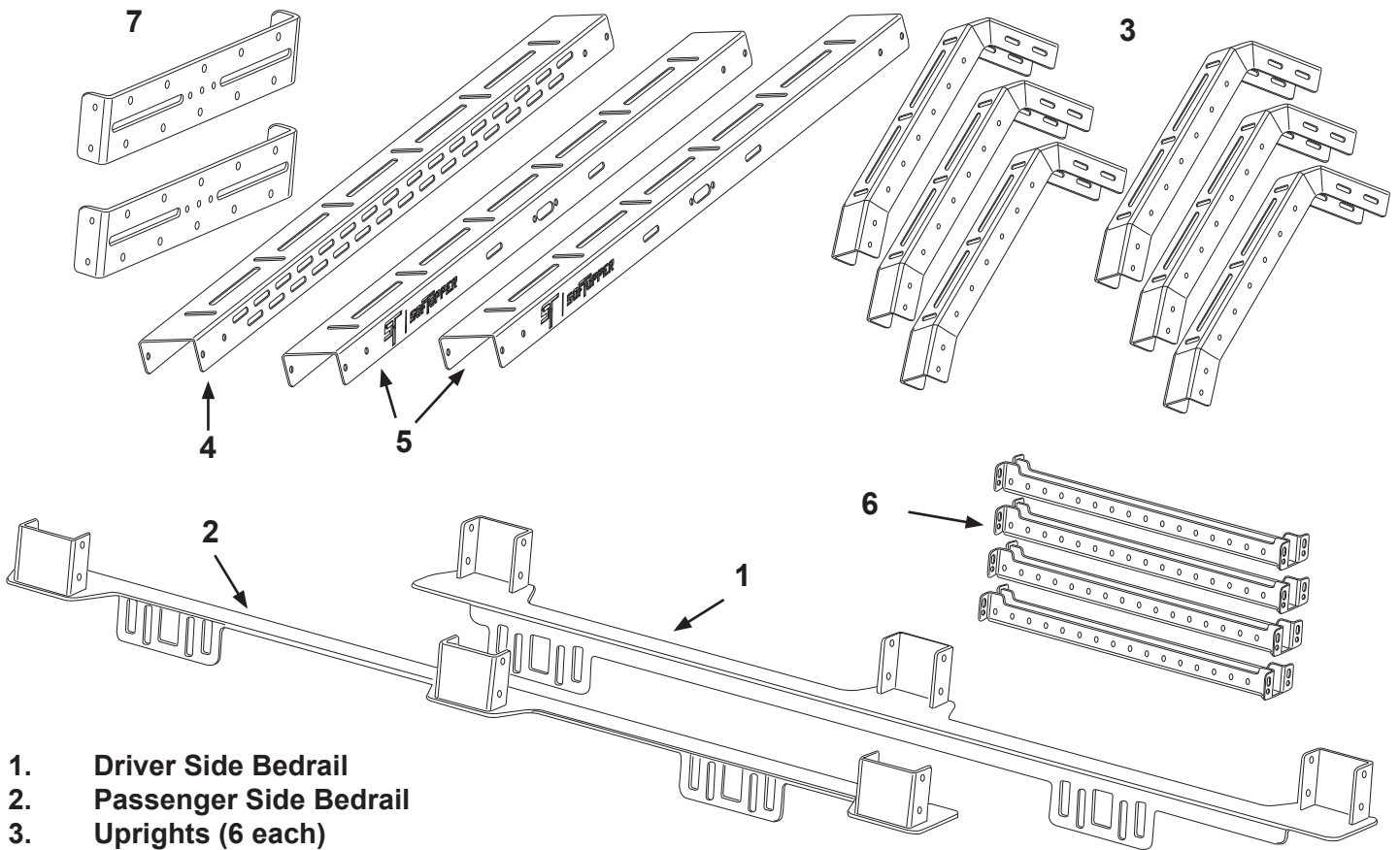

1. Driver Side Bedrail
2. Passenger Side Bedrail
3. Uprights (6 each)
4. Center Top Channel (Without Logo)
5. Front/Rear Top Channel (2 each)
6. Tent Bars (4 each)
7. Accessory Panels (2 each)

A TRUCK WITHOUT TRACK SYSTEM

1. Flat Plate (4 each)
2. Clamping Plate (4 each)
3. Carriage Bolt 3/8•16 x 1 1/2 inch (8 each)
4. 3/8 inch Flat Washer (8 each)
5. 3/8 inch Lock Nut (8 each)
6. 5/16•18 x 1 inch Bolt (77 each)
7. 5/16 inch Flat Washer (154 each)
8. 5/16•18 Lock Nut (77 each)
9. Tube of Loctite (1 each)

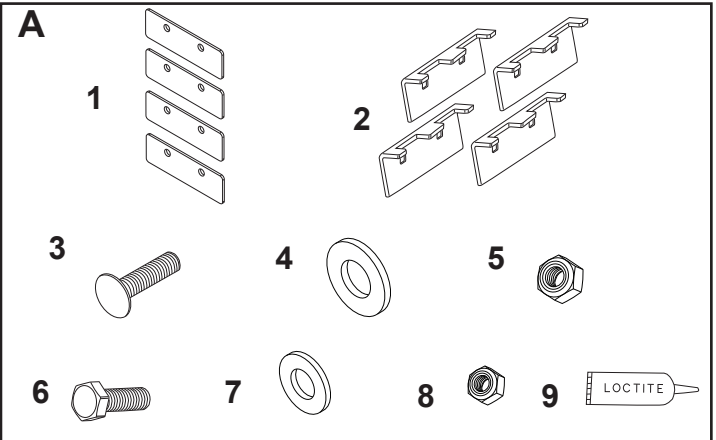

B TRUCK WITH TRACK SYSTEM

1. Track Plate (4 each)
2. Tube of Loctite (1 each)
3. 5/16•18 x 1 inch Bolt (85 each)
4. 5/16 inch Flat Washer (170 each)
5. 5/16•18 Lock Nut (85 each)
6. 5/16 inch Flat Washer (8 each)

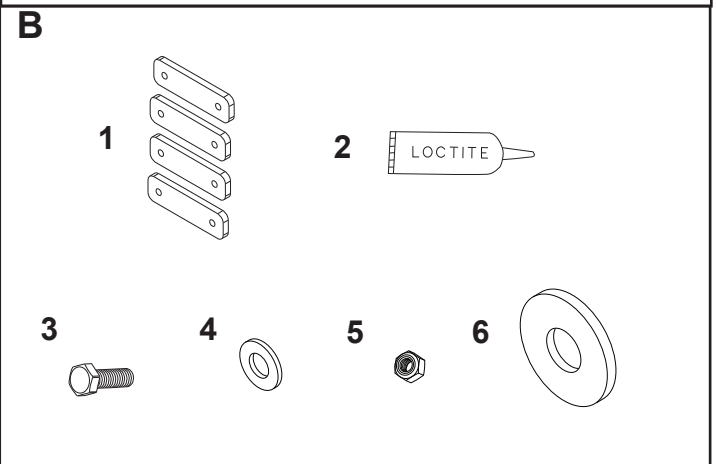

Bedrail Installation

NOTE:

The Rack and Softopper may need to be adjusted during assembly, therefore, it's best to loosely install the rack and hold off tightening the nuts and bolts until the end of the installation.

Do not overtighten the nuts and bolts.

Recommended torque;

5/16•18 = 13 ft-lbs

3/18•16 = 35 ft-lbs

1. If the Softopper is installed, remove it from the vehicle.
2. Place the bed rails on the vehicle (see photo for orientation of the bed rails).



Vehicles with track system

Place the track plates in the track rails (two per side).



Slide 2 track plates into each factory track on the vehicle.



Loosely attach the bed rail to the track plates using the 5/16 inch bolts and larger 5/16 inch flat washers.

Vehicles without track system

3. In this order, starting from the inside of the bed rail under the lip,
 - #1 clamping plate with carriage bolts
 - #2 trucks metal bed rail and plastic bed cap
 - #3 full length bed rail
 - #4 flat plate against the full length bed rail
 - #5 3/8 inch flat washer
 - #6 3/8 inch lock nut.

NOTE: Make sure you clamp to the metal lip on the truck's bed and not just the plastic bed cap.



The clamping plate with the bend goes on the inside of the truck's bed rail. Make sure the clamping plate is all of the way inside (not grabbing only the plastic bed cap)



Attach the flat plate to the carriage bolts with flat washers and 3/8 inch lock nuts. Leave loose at this time.

Attach uprights to the bed rails



Attach the uprights to the bed rails using four (4) of the 5/16 inch bolts, eight (8) of the smaller flat washers, and four (4) 5/16 inch lock nuts per upright.



Attach top channels to the uprights

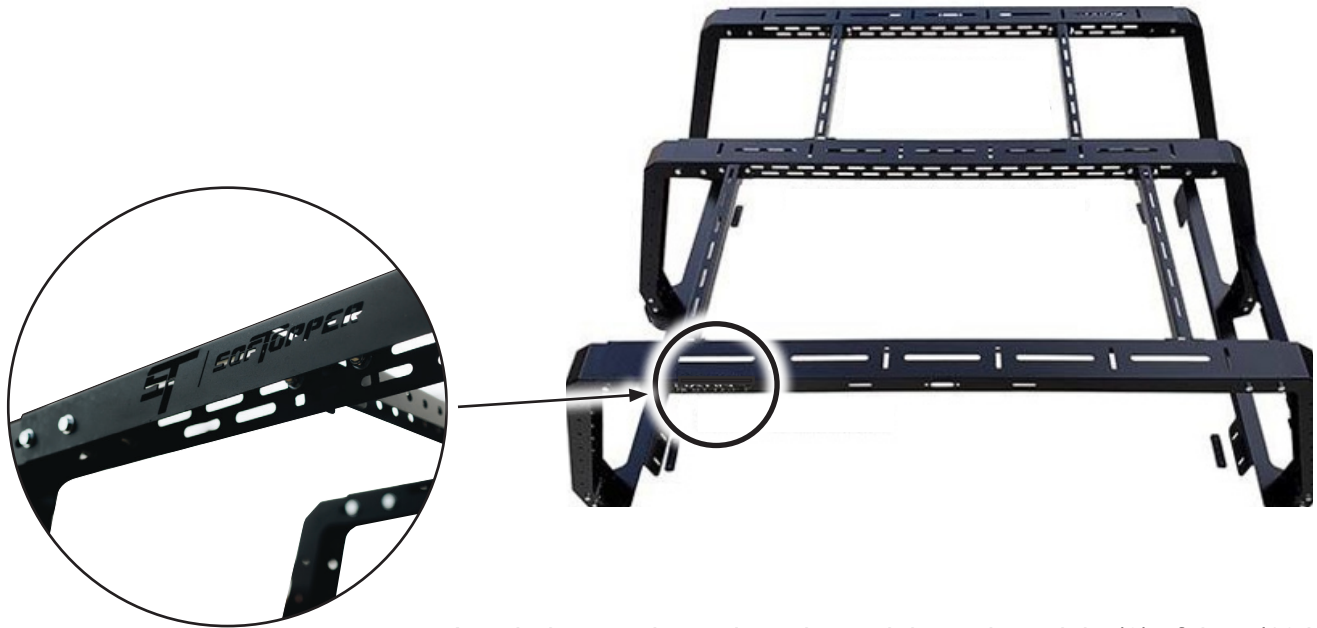

Attach the top channels to the uprights using eight (8) of the 5/16 inch bolts, sixteen (16) of the smaller flat washers, and eight (8) 5/16 inch lock nuts per top channel.

NOTE: The center channel does not have a logo cut into it. The two channels that have the logo cut into them must be installed with the logo facing forward on the front of the rack and rearward on the rear of the rack.

Attach the tent bars to the top channels



Notice, the slots are offset on the tent bars. The tent bars can be mounted with the slots in any orientation to allow for accessories with varying hole patterns .

Install the tent bars using the top or bottom holes as needed. This allows you to put the tent bars anywhere along the top channels. You only need two bolts at each end.

Attach the tent bars to the top channels using four (4) of the 5/16 inch bolts, eight (8) of the smaller flat washers, and four (4) 5/16 inch lock nuts per tent bar.

The channel opening must face down, and the slots must face up.

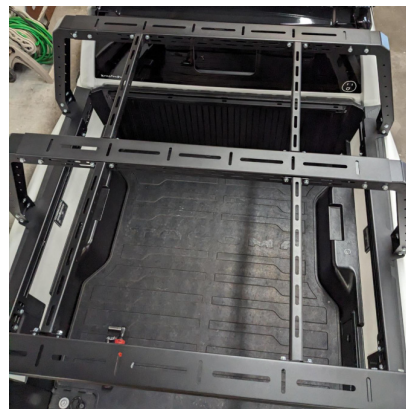

Attach accessory panels to the uprights

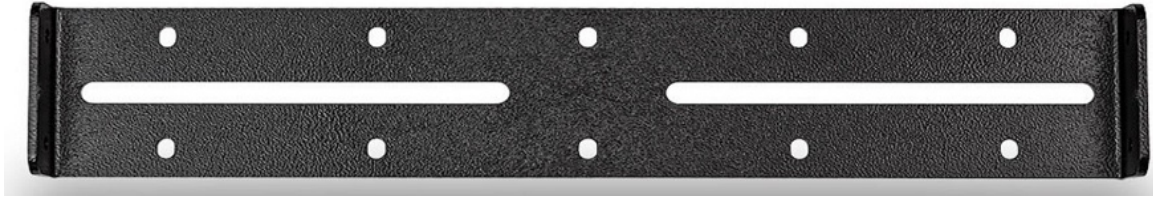

Accessory panel can be mounted anywhere. They line up with the hole patterns in the sides of the uprights. You can add as many accessory panels as needed to fit your gear. Two (2) are provided; more can be purchased separately.



Attach the accessory panels using four (4) of the 5/16 inch bolts, eight (8) of the smaller flat washers, and four (4) 5/16 inch lock nuts per accessory panel.

Now that the everything is assembled, you can tighten all of the fasteners to 13 ft-lbs **except** the bed rail mounting brackets. You may have to adjust the rack forwards or backwards to align with the softopper.

Assemble or re-assemble the softopper frame

If you removed your Softopper before the rack installation or installing the Softopper for the 1st time after the rack installation, you can re-install the Softopper at this time. Refer to the Softopper installation instruction sheet. (Some steps will vary to install with the rack).

Align the Softopper bedrails in the same position as previously installed or at the suggested starting point if installing for the first time on top of the rack bed rails. You may need to adjust the Softopper bedrails forward or rearward for best fitment.

Loosely mount the clamps as close to the recommended 10-13 inches as possible.

The Softopper folding frame and canopy will need to be assembled and in the open position. This next step is best done with a friend to help maneuver the open Softopper into the bed of the vehicle and attach the folding frame by sliding the hole of the folding frame over the pivot pin on the bed rails. You may have to move the Softopper and/or the Exo rack forward or backward to achieve the best fit for the vehicle.





Once the Softopper and the bed rack are in position, tighten the rack mounting bolts 35 ft-lbs. (13 ft-lbs if you have a track system)



Push up on the flat plate and clamping plate until they firmly meet the body of the truck under the bedrail.



Tighten the nuts to 35 ft-lbs.

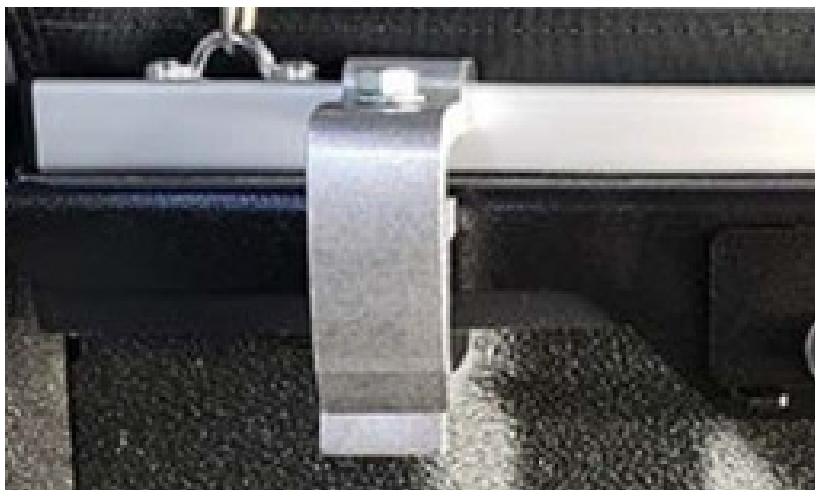

Tighten the bolts to 13 ft-lbs.

Powder Coat Disclaimer

Powder coat disclaimer, care and maintenance

Important: PLEASE READ

The Softopper® Exo Truck Bed Racks are directly exposed to debris from your front tires, as this is the only way the rack can function outside the Softopper(R). Dirt, snow, rocks, mud, road salt, and winter gravel from the road can act like a sandblaster, damaging the powder coat over time. No coating can resist constant exposure to the elements, especially in harsh climates. Additionally, some car washes use chemicals that can harm the powder coating.

Steps you can take to prevent damage and rust;

- Use mud flaps
- Use fender flares
- Wash off mud and snow
- Road salt destroys all finishes, wash the truck often if your roads are salted
- Touch up any bare metal with Krylon spray paint in matte black
- The racks are designed for regular use and enjoyment. Some occasional maintenance may be needed. To protect any exposed metal, simply touch up with paint to cover scratches from rocks or branches.

Warranty

We warrant all of our Softoppers to be free from defects in material and workmanship for a period of one year, with the exception of vinyl windows and zippers, provided there has been normal use and proper maintenance.

Vinyl Windows are warranted for a period of 3 months from the date of purchase.

Zippers are guaranteed to be in perfect working condition when leaving the factory. Due to atmospheric conditions, dirt, sand, road grime, dust, and abrasive cleaners, etc., zippers are warranted for a period of 6 months from the date of purchase.

Toyota 4 Runner, Jeep Wrangler, Blazer, Jimmy, Scout, Bronco, and RamCharger side curtain windows are warranted for 45 days from the date of purchase. Retracting or closing the top when the temperature is below 40 degrees may void the warranty on the side windows, as clear vinyl plastic can crack very easily at these temperatures. Use caution when retracting the top or cleaning off the windows in freezing temperatures.

Softopper Exo Truck Bed Racks we warrant to be free from defects in material and workmanship for a period of one year with the exception of the powder coat finish. Please see our powder coat disclaimer.

Softopper Consumer Returns Policy

We want you to be thrilled with your Softopper purchase. We are committed to providing you with the highest quality products possible, worthy of your trust and confidence.

If for any reason, you have concerns, questions, or need assistance with a product, please reach out to us: Contact us before returning it. We have found that when a product is not working as expected, a few adjustments or corrections can often set things right.

You may return a Softopper product within 30 days of your purchase, provided that the product is in its original packaging, and includes all original packaging. Please take note of our Exclusions on Returns:

We cannot accept products that are damaged due to negligence, abuse, or misuse.

IMPORTANT: ALL RETURNS MUST REFERENCE AN APPROPRIATE RGA (RETURNED GOODS AUTHORIZATION) NUMBER, WHICH MAY BE OBTAINED FROM A SOFTOPPER CUSTOMER SERVICE AGENT AT #800-810-7227, VIA LIVE CHAT, OR BY EMAILING info@softopper.com. PLEASE WRITE THE RETURN AUTHORIZATION NUMBER BELOW OUR ADDRESS ON THE OUTSIDE OF THE BOX. ANY RETURNS WITHOUT A VALID RETURN AUTHORIZATION NUMBER WILL BE REFUSED.

Returns Policy

Please contact us at #800-810-7227, via Live Chat, or email us at info@softopper.com for an RGA number and assistance with this process. Returns must have an appropriate RGA (Returned Goods Authorization) number.

- When returning a product to Softopper, please return all parts in their original packaging. All products must be returned in their original box and include all original packaging materials.
- Products that are unopened or in NEW condition are subject to a re-stocking fee equal to 5% of your order. If the merchandise has been used or damaged, the return will be subject to a restocking fee of 15%.
- Original shipping, return shipping, taxes, and handling costs are non-refundable.
- Refunds for installation are not permitted once services are rendered.
- Returns must be received by Softopper within 30 days of RGA authorization.
- Please allow 10–15 business days for us to process a return after it arrives at our offices.

Exclusions on Returns

- We cannot accept products that are damaged due to negligence, abuse, or misuse.
- We cannot accept products that have not been used in accordance with their documentation or installation instructions.

Returns of Damaged Shipments

If you receive a damaged package, please contact Softopper customer service at info@softopper.com within 30 calendar days of receipt of your package, for assistance.

Regarding damaged shipment claims:

- Please be prepared to describe the damage and provide photographs.
- Once photographs have been captured, please open the box with the inventory what is still contained inside, photographing any damaged parts.
- Softopper will replace any of the parts listed under a warranty.
- Returning a damaged shipment will follow the same procedure and policy as above.